



SF11 DECK SCALER



OPERATION & MAINTENANCE



OPERATION

General Information

Thank you for your purchase of the SF11 DECK SCALER.

Before operating the SF11 Deck Scaler, this manual must be read and understood by the operator, if in any doubt ask your supervisor before using this equipment. Failure to follow these instructions could result in damage to the Scaler and/or personal injury.

Trelawny SPT Ltd disclaims all responsibility for damage to persons or objects arising as a consequence of incorrect handling of the tool, failure to inspect the tool prior to starting work for damage or other faults that may influence the operation or safe working of the tool, or failure to follow the safety regulations listed or applicable to the job site.

The tool is primarily designed for the removal of heavy rust, paint and scale from ships decks or heavy steel surfaces.

This tool must not be used in a fixture.

The SF11 Deck Scaler is also available fitted with economy hardened steel one-piece pistons or can subsequently be fitted with other types of cutter heads. A vacuum shroud attachment is also available for the containment of air-borne dust. All versions can be used both indoors and out.

Operators should be familiar with the data given in the specification section. Please keep these instructions in a safe and accessible place.

Safety Precautions

Do wear Personal Protective Equipment including safety goggles, footwear, ear defenders and gloves. In some environments it will be necessary to wear facemasks or breathing apparatus.

Do be aware that this tool is not electrically insulated.

Do ensure that this tool is lubricated daily.

Do be aware that this tool can create dust and flying debris.

Do be aware of others working around you.

Do keep hands and clothing away from moving parts.

Do store this tool in a secure and dry environment.

Always observe safe working practices and local safety regulations at all times.

Do not allow the tool to run unattended.

Do not allow the tool to run continuously whilst not in contact with the surface being prepared.

Do not modify this tool in any way, as this will invalidate the warranty and could lead to serious injury.

Do not use this tool in potentially explosive environments.

Do not drag this tool by the air hose.

Do not use petrol (gasoline), thinners or any other high flash point solvent to clean the tool.

Please note: Unrestrained hoses can whip if they become detached.

Ensure that the work place is well ventilated. Avoid operating engine-powered compressors in an enclosed area, since engine exhaust gases are poisonous.

Risk of Hand-arm Vibration injury

These tools may cause Hand-arm Vibration Syndrome injury if their use is not adequately managed. We advise you to carry out a risk assessment and to implement measures such as; limiting exposure time [i.e. actual trigger time, not total time at work], job rotation, ensuring the tools are used correctly, ensuring the tools are maintained according to our recommendations, and ensuring that the operators wear personal protective equipment [PPE] particularly gloves and clothing to keep them warm and dry. Employers should consider setting up a programme of health surveillance to establish a benchmark for each operator and to detect early symptoms of vibration injury.

We are not aware of any PPE that provides protection against vibration injury by attenuating vibration emissions.

See 'Technical Specifications' section for vibration emission data.

Further advice is available from our Technical Department.

We strongly advise you to visit the Health & Safety Executive website <http://www.hse.gov.uk/vibration>

This site provides excellent advice and information on HAV and it includes a Hand-arm Vibration Exposure Calculator that is easy to use to work out the daily vibration exposure for each of your operators

Pre-Start Check

Air Supply:

The compressed air must be free from water or contamination. Always clear the air hose before connection to the tool.

Ensure that no moisture (condensation) is present. Ensure that a minimum 19mm (3/4") bore airline is used and that all couplings are tight and secure. If possible try to limit the length of airline to 33 ft. (10 metres)

(Air consumption is shown under **Technical Specifications** at the end of these instructions).

Where extra length airline is necessary, each additional 50 ft. (15 metres) of airline used, will drop the pressure at the tool by approximately 3 psi.

Correct operating pressure for this tool is 6.2 bar (90psi)

Do not let the operating pressure fall below 5.5bar (80p.s.i.) or rise above 6.9bar (100 psi) absolute maximum.

The compressor must be able to supply a minimum of 47 lps (100cfm)

In particularly cold weather it is recommended that a proprietary anti-freeze lubricating oil is used.

Note: A vacuum shroud is not available on the standard SF11. This can only be fitted to Heavy Duty version.

Starting work

Prior to operating the tool check: -

That all fittings are secure, free from leaks and that air hoses are in good condition.

That all parts of the tool are fully screwed together and secure, if in any doubt ask your supervisor before using this equipment.

That a liberal amount of lubricant has been put into the air inlet of the tool. (See recommended lubricants)

Safe use of this tool requires a solid stance and secure foothold; the operator must adopt a firm and stable position at all times.

Remove the lifting pin from the bottom of the handle to release the handle, refit in to the block-lifting bracket to prevent its loss. Never run the tool with the handle fastened to the main body. The most efficient scaling action is to move the tool back and forth until the desired finish has been achieved. Never run the tool continuously in the same place as this will severely mark the surface and may cause cutter head damage.

To operate the tool simply turn the ball valve so that the lever is in line with the handle. If the tool is new, optimum performance will be achieved after 15mins "running in" of the brush seals (29). Complete a small area noting the performance; stop the machine, inspect the finish produced. **To switch off**, simply return the ball valve lever to 90° to the handle whilst continuing to move the tool back and forth. Handled correctly the SF11 Deck Scaler will work quickly and efficiently. Gloves and personal protective equipment must be worn when using this tool. The tool will ride irregularities of up to 5mm (1/4"). Anything greater will risk cutterhead damage. Care must be taken to avoid damaging or tripping over the air hose. Once the task is completed, return handle to the upright position and insert the handle-locking pin (11) for transportation.

Servicing

Only a competent person, in a suitably equipped workshop, must carry out maintenance.

Disconnect the tool from the air supply before carrying out any of the following operations.

Dismantling

Clean all debris from the exterior of the tool.

Head Removal – Taper Fit Pistons

Lay the machine down on its side. Unscrew and remove screwed cap (25). Remove spring cap (27) and spring (26). From the bottom of the unit push on the cutter head and remove the piston assembly. Repeat for all other cylinders. Place the head removal washer between the cutter head and the cylinder, place cylinder assembly on a flat solid surface with the cutter head upper most, insert the removal pin into the cutter head hole so that it rests on the end of the piston. Wearing safety glasses, deliver a sharp blow to the head of the pin with a medium sized hammer and the cutter head will be released from the piston.

Piston and Cylinder removal One Piece Pistons

Unscrew and remove screwed cap (25). Remove spring cap (27) and spring (26) from the bottom of the scaling head push up and remove the piston (30) cylinder (28) and brush seal (29) as an assembly. Repeat for all other cylinders.

SERVICING

Wheel removal

Lay tool on side. Close the split pin (24) and remove the pin, remove washer (20) and slide the wheel (23) from the axle.

Handle Assembly from Sub-Frame

Remove locking pin (11) to free handle. Lay tool down with hoses uppermost. Unscrew the connector on the hose (7) from the adaptor nearest to the scaling head. Select two 15/16" A/F spanners to fit bolt (16) and nut (15). Unscrew and remove both nut (15) and washer (17), withdraw bolt (16) and washer (17).

Sub-Frame from Scaling Head

Repeat the above, then select a 3/4" A/F spanner and unlock nut (19) unscrew nut and remove both nut and washer (20). Repeat for other side.

Ball Valve from mounting

Unscrew hose fittings from ball valve (6) unscrew 4 nuts (5) and remove u-bolts (3) and mounting brackets (4).

Lifting plate from Handle Assembly

Select a 13mm A/F spanner to suit nut (8) and a 6mm A/F Allen Key to suit cap head screw (9) and unlock screw (9). Remove washer (8a) and repeat for other screw.

Assembly

Ensure all parts are clean and that all internal parts have a film of air tool oil, unless specified otherwise. Avoid lubricating oil contaminating the threads of the body, and the screw cap. These will require securing with a thread-locking adhesive. Replace any parts that show signs of wear. If the tool has been fully serviced it is recommended to change anti-vibration pads (18) and (21).

Piston, Cylinder and Brush Seal - One piece pistons

Fit piston (30) into cylinder (28) as shown in the service layout. Fit new brush seal (29) over piston and into the recess on the cylinder.

Taper Fit Head Pistons

Ensure that all traces of oil/grease are removed from the new cutter head taper and piston taper using a suitable oil free solvent. Fit the piston into the cylinder as shown in the service layout. Fit a new brush seal into the cylinder recess. Select a cutter head and place on to the taper of the piston. Place the assembly on to a solid flat surface, and with the cutter head uppermost, deliver a sharp blow with a soft faced hammer to seat the cutter head onto the piston taper.
(The use of a hard faced hammer will damage the tungsten carbide inserts).

Assembly of Scaling Head

Removal all traces of oil from screwed cap and cylinder block threads. Select a cutter head/piston/cylinder/brush seal assembly and apply a few drops of air tool oil to the top of the piston and fit into the body (30), repeat with the other assemblies. Fit spring (26) into a screwed cap (25) and fit spring cap (27) into screwed cap, as shown in the service layout. Apply a small bead of Loctite 243 (Threadloc) or its equivalent to the first two threads of the spring cap and screw down by hand, fully tighten the screwed cap using a suitable spanner, to a torque of 81.5 Nm (60 lb/ft).

Sub-frame to Scaling Head

Align mounting holes on sub-frame (22) with anti-vibration pad (21) studs and fit as shown in service layout. Fit washer (20) and locknut (19) to both studs and fasten both nuts down to a torque of 40lb ft

Wheel to Sub-frame

Slide wheel (23) onto sub-frame axle, fit washer (20) and insert a new split pin (24) into the hole. Separate legs on split pin and bend round with pliers or otherwise. Repeat on the other wheel.

Handle to Sub-frame

Fit washer (17) to bolt (16) and align all holes through chassis and anti-vibration mountings (18) guide the bolt through until it appears at the other end. Fit washer (17) to threaded end of bolt and fit nut (15). To ensure that the sub-frame does not twist or buckle through over tightening of the nyloc nut (15), tighten so that not more than 3/8" (10mm) of thread it protruding from the nyloc nut (15). Select a 13mm A/F spanner to suit (8) and a 6mm A/F Allen key to suit caphead screw (9). Slacken off both bolts (9) and nuts (8) align the lifting plate (10) to the lifting block (12) and insert the locking pin (11). Ensure that the pin hole is central and the locking pin can be removed and inserted easily, adjust as necessary.

Ball Valve Mounting

Fit one of the two u-bolts (3) around ball valve (6) and through bracket (4) so that the ball valve is in line with the handle tube. Guide the u-bolt (3) into holes in the mounting flange so that the ball valve is in line with the handle tube. Fit two nuts (5) finger tight to hold the unit in place. Repeat with the second u-bolt and bracket. Align the ball valve handle with the main handle (14). Select a 13mm A/F spanner and fasten evenly the four nuts (5) until the valve is secure.

Lifting Plate

Align holes in the lifting plate with the holes on that of the lifting plate flange, ensuring that the position of the lifting plate (10) is central to the

main handle (14). Insert the bolt (9) and fit a washer (8a) and nut (8). Fit the handle-locking pin (11). Select a 13mm A/F spanner to suit (8) and a 6mm A/F Allen key to suit caphead screw (9). Tighten both nut and bolts (8) & (9) ensuring that the pin hole is central and the locking pin can be removed and inserted easily.

Machine storage

Short period storage: up to 3months.

Clean the outside of the machine and inspect the cutter heads for wear, replace any worn parts as required. Insert a liberal quantity of air tool oil through the air inlet and run briefly to ensure that internal components are coated with oil. Cover the machine to protect it. Store the machine in a dry place.

Long period storage: over 3months

Clean outside of machine, inspect the cutter heads for wear, replace any worn parts as required. Remove any build up of material from the cutter head area. Insert a liberal quantity of air tool oil through the air inlet and run briefly to ensure that internal components are coated with oil. Lubricate the exposed part of the piston and cylinder. (See recommended lubricants) Cover the machine to protect it. Store the machine in a dry place. After a further 3 months have elapsed, insert oil into the air inlet as previously described. When next used, continue as per "Starting work section".

Machinery Directive Information

This tool has been designed and produced in accordance with the following directives:
2006/42/EC Machinery Directive
and applicable harmonised standard:
EN ISO 1 1148-4:2010

If your company has any problem with our products or would like to discuss the possibility of an improvement being made to them, then please do not hesitate to contact us. Your comments are both important and appreciated.

The company operates a policy of continuous product development and refinement and therefore reserves the right to change technical specifications and product designs without giving prior notice.

All rights reserved. Any unauthorised use or copying of the contents or part thereof is prohibited. This applies to trademarks, model denominations, part numbers and drawings. Use only genuine Trelawny spares. The use of non-Trelawny spare parts invalidates the warranty.

Trouble Shooting

FAULT	CAUSE	ACTION
Machine bounces in use	Air pressure too high.	Ensure that the air pressure is set at 90psi. (6.3bar). If the air pressure cannot be controlled, close off the SF11 on/off valve slightly until the machine runs smoothly.
Machine performance slow	Worn Cutter Heads	Replace Cutter Heads (Cutter Head life is approximately 100hrs use)
Machine drags on deck or floor	Insufficient air supply	Ensure that the compressor can supply at least 100cfm (free air) at 90psi. The SF11 Deck Scaler requires 70cfm
	Hose bore too small	Ensure that the hose bore is 3/4" (19mm).
	Hose run too long	Each 50 ft. (15 metres) of airline used, will drop the pressure by approximately 3 psi.
	Worn Pistons and/or cylinders.	Replace piston and cylinders
If the problem has not been cured by any of the above actions, contact your local dealership or agent for assistance.		

EXPLODED VIEW

TRELAWNY™
United Kingdom Online Sales

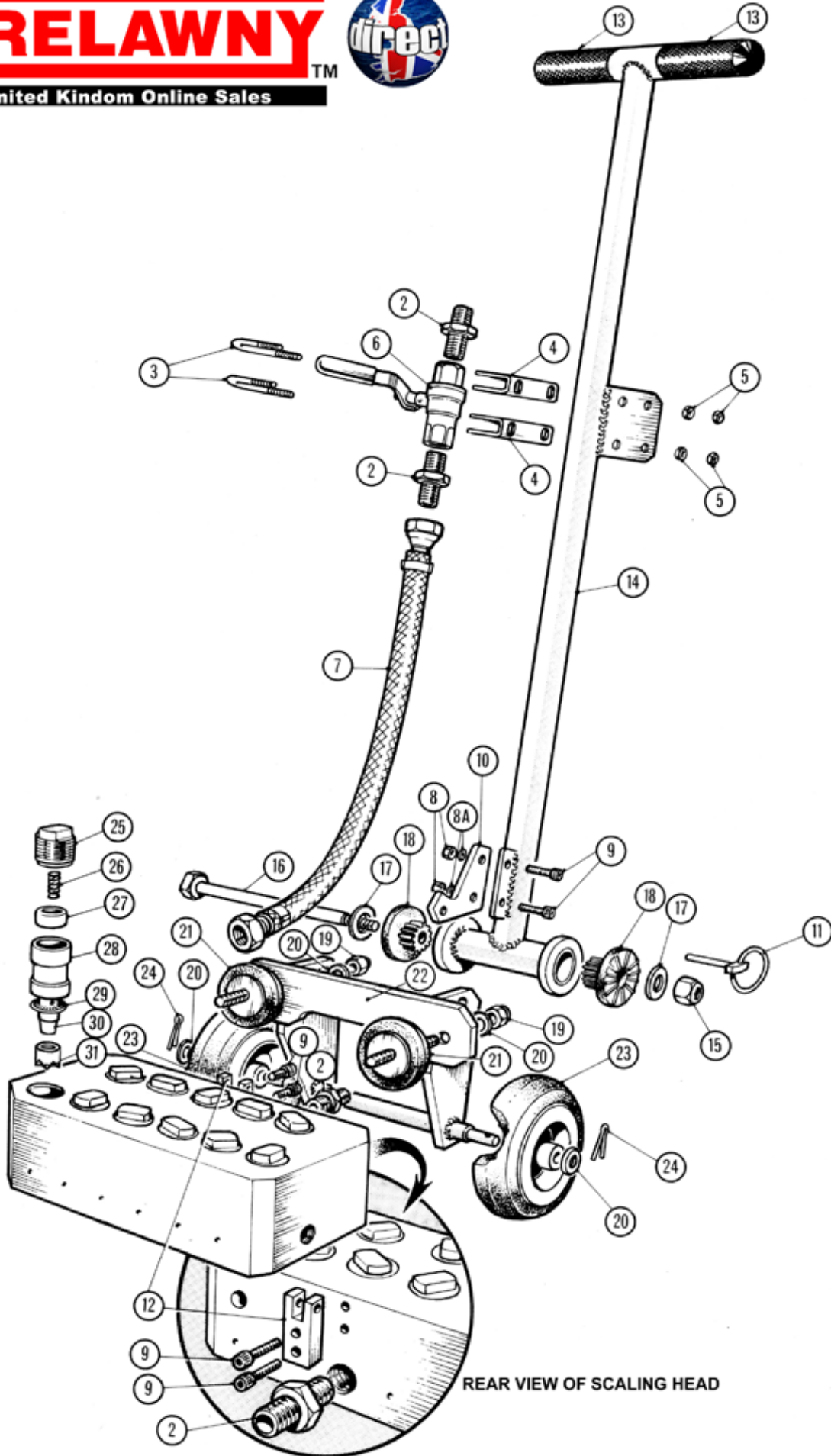

REAR VIEW OF SCALING HEAD

Parts list

Item No	Part No	Description	Item No	Part No	Description
2	826.5004	Adaptor 3/4" BSP	20-24	491.1000	Wheel Assembly (set of 2)
3-5	491.2100	U Bolt Assembly (set of 2)	25	615.5341	Screwed Cap
6	828.1000	Ball Valve	26	712.5301	Compression spring
7	719.0750	Armoured Hose Assembly with Couplings	27	615.5361	Spring Cap
8-12	491.3000	Lifting Bracket Assembly	28	613.5301	Cylinder
11	490.2100	Locking Pin (set of 2)	29	614.5301	Brush Seal
13	490.0100	Handle Grip (set of 2)	30	612.5301	Piston (Taper fit)
14	422.0110	Handle including grips	31	426.5351	Cruciform cutter head – (Taper fit)
15-17	491.2000	Handle Mounting Assembly	or	606.5303	Beryllium cutter head – (Taper fit) –spark resistant
18	490.1000	Rubber Handle Mounting			
19-21	491.0100	Rubber Cylinder Block Mtg Assembly (set of 2)			
22	440.0130	Sub Frame			NOT SHOWN
				437.0100	Vacuum Shroud assembly
				731.0120	Polyurethane seal

Technical Specifications

Description	Metric	Imperial
Piston diameter	27mm	1.06"
Piston length	89mm	3.50"
Stroke	26.5mm	1.04"
Blows per minute	2300 x 11	
Air pressure - (3/4" BSP Air Inlet)	6.2 bar	90psi
Air consumption	33 lps	70cfm
Length (handle lowered)	1300mm	51.2'
Height (Handle raised)	1230mm	48.4'
Work head dimensions	285mm (11.2")L x 150mm (5.9")W x 180mm (7.1")D	
Cutting width	252mm	9.9"
Cutting width to edge	15mm	0.59"
Weight	37.2kg	82lbs
Noise level db(A)	LpA	103.1
	LwA	113.1
Vibration (AEQ) at the Handle Bar*	a=5.8 m/s ² (K= +40% -0%)	

Risk of Hand Arm Injury

Because of various factors, the range of vibration emission during intended use of this tool is expected to be between 5.8m/s² – 8.1m/s² for this Scaler. The vibration is dependent on the task, the operators grip, and the feed force employed etc.

Noise level measured in accordance with: EN ISO 15744: 1999

Vibration measured in accordance with: EN ISO 28927 and EN ISO 20643

(K) Equals the factor of uncertainty, which allows for variations in measurement and production. Vibration data figures are tri-axial, which gives total vibration emission.

*In general all vibration values are considered to be -0% +40% (k = factor of uncertainty)

Trelawny SPT Ltd operates a policy of continuous product development and refinement and therefore reserves the right to change technical specifications and product designs without giving prior notice.



site: www.trelawnydirect.com
 email: sales@trelawnydirect
 call: 01698 333200

Trelawny tools are thoroughly tested under specified conditions in accordance with applicable internationally recognised standards. When a tool is used on site the conditions may not be the same as those used in Trelawny tests.

Trelawny Surface Preparation Technology operates a policy of continuous product development and refinement and therefore reserves the right to change technical specifications and product designs without giving prior notice.

© Copyright 2009, Trelawny SPT Limited, CV31 1XT, UK All rights reserved. Any unauthorised use or copying of the contents or part thereof is prohibited. This applies to trademarks, model denominations, part numbers and drawings. Use only genuine Trelawny spares.

The use of non-Trelawny spare parts invalidates the warranty.