

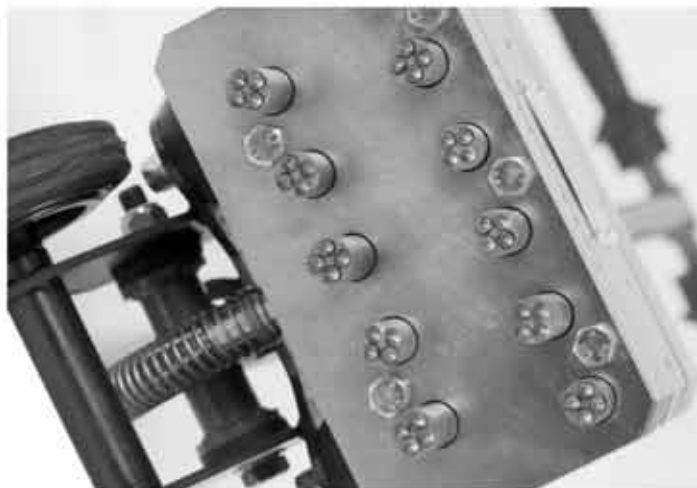

MHS11 MULTI-HEADED SCABBLER



OPERATION & MAINTENANCE



OPERATION

General Information

Thank you for your purchase of the Multi-headed Scabbler.

Before operating the Multi-headed Scabbler, this manual must be read and understood by the operator, if in any doubt ask your supervisor before using this equipment. Failure to follow these instructions could result in damage to the Scaler and/or personal injury.

Trelawny SPT Ltd disclaims all responsibility for damage to persons or objects arising as a consequence of incorrect handling of the tool, failure to inspect the tool prior to starting work for damage or other faults that may influence the operation or safe working of the tool, or failure to follow the safety regulations or applicable to the job site.

The tool is primarily designed for concrete reduction, and the removal of laitance from concrete floors, but may also be used for the removal of paint or epoxy floor coatings, it can be used both indoors and out.

This machine must not be used in a fixture.

Note:

Bush Hammer style headed pistons are best suited to concrete reduction and for laitance removal; these may reduce the likelihood of damage to the aggregate, ensuring that a stronger bond is created with the next fill or finish layer.

Cruciform headed pistons are suited to the reduction of concrete or where a smoother finish is required, these will reduce the aggregate as well as the concrete surface leaving a relatively flat surface, these are also suitable for the removal of paint and epoxy coatings.

Operators should be familiar with the data given in the specification section.

Please keep these instructions in a safe and accessible place.

This tool must not be used in potentially explosive atmospheres.

Where a vacuum shroud assembly is supplied separately, see the instructions under "Servicing" for fitting.

Manual Handling

The complete tool weighs approximately 70kg (155lbs).

Where possible use a hoist with correctly rated lifting equipment to connect to the supplied lifting eyebolt fitted on the top of the MHS11 Scabbler.

Ensure that the eyebolt is screwed down to its shoulder and has been tightened using a bar no longer than 150mm (6.00").

Always ensure the handle is locked and secure during any handling operation.

Always apply local health and safety regulations with regard to manual handling.

Safety Precautions

Do wear Personal Protective Equipment including safety goggles, footwear, ear defenders and gloves. In some environments it will be necessary to wear facemasks or breathing apparatus.

Do be aware that this tool is not electrically insulated.

Do ensure that this tool is lubricated **daily**.

Do be aware that this tool can create dust and flying debris.

Do be aware of others working around you.

Do keep hands and clothing away from moving parts.

Do store this tool in a secure and dry environment.

Always observe safe working practices and local safety regulations at all times.

Do not allow the tool to run unattended.

Do not allow the tool to run continuously whilst not in contact with the surface being prepared.

Do not modify this tool in any way, as this will invalidate the warranty and could lead to serious injury.

Do not use this tool in potentially explosive environments.

Do not drag this tool by the air hose.

Do not use petrol (gasoline), thinners or any other high flash point solvent to clean the tool.

Please note: Unrestrained hoses can whip if they become detached.

Ensure that the work place is well ventilated. Avoid operating engine-powered compressors in an enclosed area, since engine exhaust gases are poisonous.

Recommended lubricants

Oil the tool daily before use. Put a liberal quantity of one of the following air tool lubricants through the air inlet.

SHELL	Naturelle HF
CASTROL	Carelube HTG 22

Cleaning

At intervals of no more than 100 hours use, or if operation becomes unproductive, or if any of the pistons shows signs of sticking, dismantle and clean with highly refined paraffin. Replace any worn components as necessary.

Immediately after cleaning, thoroughly oil the tool with one of the recommended lubricants.

Risk of Hand-arm Vibration injury

These tools may cause Hand-arm Vibration Syndrome injury if their use is not adequately managed. We advise you to carry out a risk assessment and to implement measures such as; limiting exposure time [i.e. actual trigger time, not total time at work], job rotation, ensuring the tools are used correctly, ensuring the tools are maintained according to our recommendations, and ensuring that the operators wear personal protective equipment [PPE] **particularly gloves and clothing** to keep them warm and dry.

Employers should consider setting up a programme of health surveillance to establish a benchmark for each operator and to detect any early symptoms of vibration injury.

We are not aware of any PPE that provides protection against vibration injury by attenuating vibration emissions.

See 'Specifications' section for vibration emission data.

Further advice is available from our Technical Department.

Pre-Start Check

The compressed air supply must be free from water and dirt. The installation of a filter/regulator/lubricator air preparation set (with moisture trap) adjacent to the tool is **strongly recommended**. Always clear the air hose

before connection to the tool. Ensure that no moisture (condensation) is present in the air hose. Ensure that a minimum 19mm (3/4") bore air hose is used and that all couplings are secure; leak free and in good condition. Limit the length of air hose to 15M (50ft). Where extra length is necessary, for each additional 15M (50ft) of air hose used, the pressure drop is approximately 0.16bar (3psi).

Correct operating pressure is 6.2bar (90 psi).

Do not let the operating pressure fall below 5.5bar (80p.s.i.) or rise above 6.9bar (100 psi) absolute maximum.

Preferably, the compressor should be able to supply a minimum of 33L/s (70cfm) free air. In particularly cold weather it is recommended that a proprietary anti-freeze lubricating oil be used.

Starting Work

Prior to operating the tool check: -

That all fittings are secure, free from leaks and air hoses are in good condition.

That all parts of the tool are fully screwed together and secure, if in any doubt ask your supervisor before using this equipment.

That a liberal amount of lubricant has been put into the air inlet of the tool. (See recommended lubricants)

Safe use of this tool requires a solid stance and secure foothold; the operator must adopt a firm and stable position at all times. Depress the foot mechanism (24) to release the handle. Never run the tool with the handle fastened to the main body. To operate the tool turn the ball valve on the handle to the fully opened position and immediately start to move the tool back and forth, continue until the desired finish is achieved. Never run the tool continuously in the same place, as the cutterheads will dig into the surface. If the tool is new, optimum performance will be achieved after 15mins "running in" of the brush seals (48). **To switch off**, simply return the ball valve lever to 90° to the handle whilst continuing to move the tool back and forth, return handle to the upright position, ensuring foot release has engaged. Complete a small area noting the performance; stop the machine, inspect the finish produced. Handled correctly the MHS11 Multi-headed Scabbler will work quickly and efficiently.

Gloves and personal protective equipment **must** be worn when using this tool. The tool will ride irregularities of up to 13mm (1/2"). Anything greater will risk cutterhead damage. Care must be taken to avoid damaging or tripping over the air hose.

Servicing

Only a competent person, in a suitably equipped workshop, must carry out maintenance.

Disconnect the tool from the air supply before carrying out any of the following operations.

Dismantling

After ensuring that the air supply is turned off, remove the tool from the airline. Thoroughly clean the outside of the tool prior to dismantling.

Cutter Head Removal (Two Piece)

To change the replaceable cutter heads without completely dismantling the tool.

SERVICING

Remove the eyebolt (38) from the cylinder head, then lay the tool on its front face, unlock the handle and pull the cylinder block onto its top face; select a 19mm A/F (3/4") spanner for the flats of the piston (42) and a 27 mm spanner for the flats on the cutterhead (50). Unscrew the cutterhead and remove from the piston. It is also advisable at this point to replace the brush seals, select a 19mm A/F (3/4") spanner and unscrew the 5 x hexagon head bolts (49). Remove the bolts and sealing plate (49/47). Remove the worn brush seals (48), which may need prising out of their recesses.

See: *Assembly of Exhaust Chamber/Cutter Heads.*

Cutter Head / Piston removal (One Piece)

To replace the one-piece pistons (52), place the cylinder block on wooden blocks so that the cutterheads are clear of the floor. Unhook the main handle from the chassis and lay the handle on the floor. Using a 19mm (3/4") spanner unscrew and remove the two-nyloc nuts (29) from the upper vibration reducing mountings. Using a 10mm Allen key, remove the 7 x socket headed bolts (41) from the cylinder head (39). Take care when removing the cylinder head as it weighs 16.4kg (36.0lbs), take extreme care against trapping your fingers when lifting and placing the cylinder head down, use a hoist or other suitable lifting equipment whenever possible. An eyebolt (38) is supplied fitted to the cylinder head for this purpose. Remove the O'Rings from the cylinders and remove the piston and cylinder as an assembly. Inspect the components for wear paying particular attention to the small bore of the cylinder.

Exhaust Chamber removal

Remove replaceable cutterheads, if fitted (50), sealing plate (47) and brush seals as in "Cutterhead/Piston removal section". Remove the exhaust chamber and clean out any dust that may have accumulated inside the chamber.

Removing Sub-Frame from Cylinder Block

Lay the tool on its front, with the handle uppermost, select two 32mm (1 1/4") Spanners and unscrew the hose (60) connector from the lower ball valve adapter (55). Select a 19mm (3/4") A/F spanner and unscrew the 4 x locknuts (29) securing the chassis to the vibration reducing mountings (31) and remove all nuts and washers (29/30).

Cylinder Head removal

Repeat the above, place the cylinder block on wooden blocks so that the cutterheads are clear of the floor.

Select a 10mm A/F hexagon key and unscrew the 7 x caphead screws (41). Withdraw the screws and lift the head clear of the cylinder block. Take care when removing the cylinder head as it weighs 16.4kg (36.0lbs), take extreme care against trapping your fingers when lifting and placing the cylinder head down, use a hoist or other suitable lifting equipment whenever possible. An eyebolt (38) is supplied fitted to the cylinder head for this purpose.

Removing Ball Valve from its mounting

Select two 32mm (1 1/4") Spanners and unscrew the hose (60) connector from the lower ball valve adapter (55). Unscrew hose fittings from ball valve unscrew the 4-nyloc

nuts (59) and remove the u-bolts (57) and mounting brackets (58).

Removal of Handle from Sub-Frame

Lay the tool on its front, with the handle uppermost. Select two 24mm (15/16") A/F spanners and unscrew and remove nut (25) and washer (27), and withdraw bolt (26) and washer (27). Depress the foot handle release lever and remove the handle from the subframe.

ASSEMBLY

Assembly is generally the reverse of dismantling. Before assembling, ensure all parts are clean and all internal parts have a film of air tool oil. Replace any parts that show signs of wear. If the tool is being fully serviced it is recommended to change anti-vibration mountings (31) and (28), along with the O'Rings (44) and the brush seals (48). It is good practice to replace the split pins (33) and locknuts (29) and (25) during assembly.

Assembly of Pistons / Cylinder Head

Set the cylinder block in the upright position, carefully placing supporting blocks underneath to aid assembly, take care not to block the exit holes for the pistons.

Cutter Head / Piston replacement (Two Piece)

Fit the pistons (42) into the cylinders (43) and insert all pairs into the cylinder block as per service layout. Fit a new O'Ring (44) into each of the recesses on the outside of the cylinders on top of the cylinder block. Put a few drops of recommended lubricating oil on top of each piston. The cylinder head is very heavy, carefully lower it into place taking care not to disturb the O'Rings or trapping your fingers. Insert the 7 cap head screws (41) and tighten initially by hand, tighten to a torque of 55Nm (40lbs/ft).

Cutter Head / Piston replacement (One piece)

Fit the pistons (52) into the cylinders (43) and insert all pairs into the cylinder block as per service layout. Fit a new O'Ring (44) into each of the recesses on the outside of the cylinders on top of the cylinder block. Put a few drops of recommended lubricating oil on top of each piston. The cylinder head is very heavy, carefully lower it into place taking care not to disturb the O'Rings or trapping your fingers. Insert the 7 x cap head screws (41) and tighten initially by hand, tighten to a torque of 55Nm (40lbs/ft).

Assembly of Exhaust Chamber / Cutter Heads

Carefully turn the block assembly over on to the cylinder head (39). Lower the exhaust chamber (46) into position with the cavity nearest the block (45). Fit new brush seals (48) into the brush seal recesses and lower the sealing plate (47) into position with the brush seal recesses nearest the block. If a brush seal is loose in the recess, pull the brush seal apart slightly to make it a tighter fit. Insert hexagon head bolts (49) through sealing plate (47), exhaust chamber and into cylinder block (45). Tighten initially by hand, then torque the bolts down to 80 Nm (60lb.ft.). If fitted, screw on the cutter heads (50) initially by hand, select a 19mm A/F (3/4") spanner for the flats of the piston (42) and a 27 mm

spanner for the flats of the cutter head (50), ensuring that the new heads are tightened to torque of 55Nm (40lbs/ft) and that both mating faces are in contact with one another.

Sub-frame to Cylinder Block / Head assembly

Align mounting holes on sub-frame with anti-vibration pad (31) studs and fit as shown in service layout. Fit washer (30) and locknut (29) to both studs and fasten by hand. Screw both nuts down to a torque of 40 lb/ft.

Wheel to Sub-Frame

Slide wheel (35) onto sub-frame axle, fit washer (34) and insert a new split pin (33) into the hole. Separate legs on split pin and bend round with pliers. Repeat for the other wheel.

Handle to Sub-Frame

Fit new anti-vibration rubber mountings (28) to the holes in either side of the handle (19) and slide assembly into position between the axle arms of the subframe (32), fit washer (27) to bolt (26) and align all holes to allow the insertion of the bolt as shown in the service layout. Guide bolt through anti-vibration pads (28) until it appears at the other end. Fit washer (27) to threaded end of bolt and fit nut (25). To ensure that the sub-frame does not buckle through over tightening and that the vibration rubbers are set correctly, tighten until both washers are no longer free to rotate.

Ball Valve Mounting

The ball valve should be fitted so that the valve is open when in line with the handle. Fit one of the two u-bolts (57) around ball valve (56) and through u-bolt clamping bracket (58). Guide the u-bolts through the holes in the mounting flange on the handle. Fit 2 x nuts (59) finger tight to hold the unit in place. Repeat with second u-bolt and bracket. Align the ball valve lever with the main handle. Select a 13mm A/F spanner and fasten evenly four nuts (59) until valve is secure.

Vacuum Shroud

To fit the optional vacuum shroud assembly (51) remove the eyebolt with a suitable bar, then lay the tool on its front face, unlock the handle and pull the cylinder block onto its top face. Select a 19mm (3/4") A/F socket and unscrew and remove the 5 x hexagon bolts (49). Select an 8mm A/F (5/16") spanner and unscrew completely the front 3 x hexagon head screws (53) and the associated front clamp plate (52). Thread the tube of the vacuum shroud assembly (51) through the subframe (32). Align the holes and secure using the 5 x 10mm cap head bolts supplied with the vacuum shroud. Refit the clamp plate (52) with the supplied screws (53) ensure that the neoprene seal is square and securely clamped. For dust free working it is recommended that a Trelawny recommended vacuum system be connected to the vacuum shroud assembly.

Disposal

Dismantle into component form for disposal according to material composition and disposed of using waste recycling processes specified by local regulations.

Note: Flammable material such as plastic, rubber or composite materials must not be incinerated but should be disposed of using normal industrial waste disposal processes.

SERVICING continued

Machine storage

Short period storage: up to 3months.

Clean the outside of the machine and inspect the cutter heads for wear, replace any worn parts as required.

Remove any build up of material from the cutter head area.

Insert a liberal quantity of air tool oil through the air inlet and run briefly to ensure that internal components are coated with oil.

Cover the machine to protect it. Store the machine in a dry place.

Long period storage: over 3months

Clean outside of machine, inspect the cutter heads for wear; replace any worn parts as required.

Remove any build up of material from the cutter head area.

Insert a liberal quantity of air tool oil through the air inlet and briefly run to ensure that internal components are coated with oil. Lubricate the exposed part of the piston and cylinder. (See recommended lubricants)

Cover the machine to protect it. Store the machine in a dry place.

After 6 months have elapsed, check the condition of the hose then insert a liberal quantity of air tool oil into the air inlet as previously described and briefly run to ensure that internal components are coated with oil.

Prior to using the machine again check the condition of the hose and the vibration mountings for signs of perishing etc, replace if suspect, continue as per the "before use" instructions.

When next used, continue as per "Pre-Start Check" section.

Exploded View 1

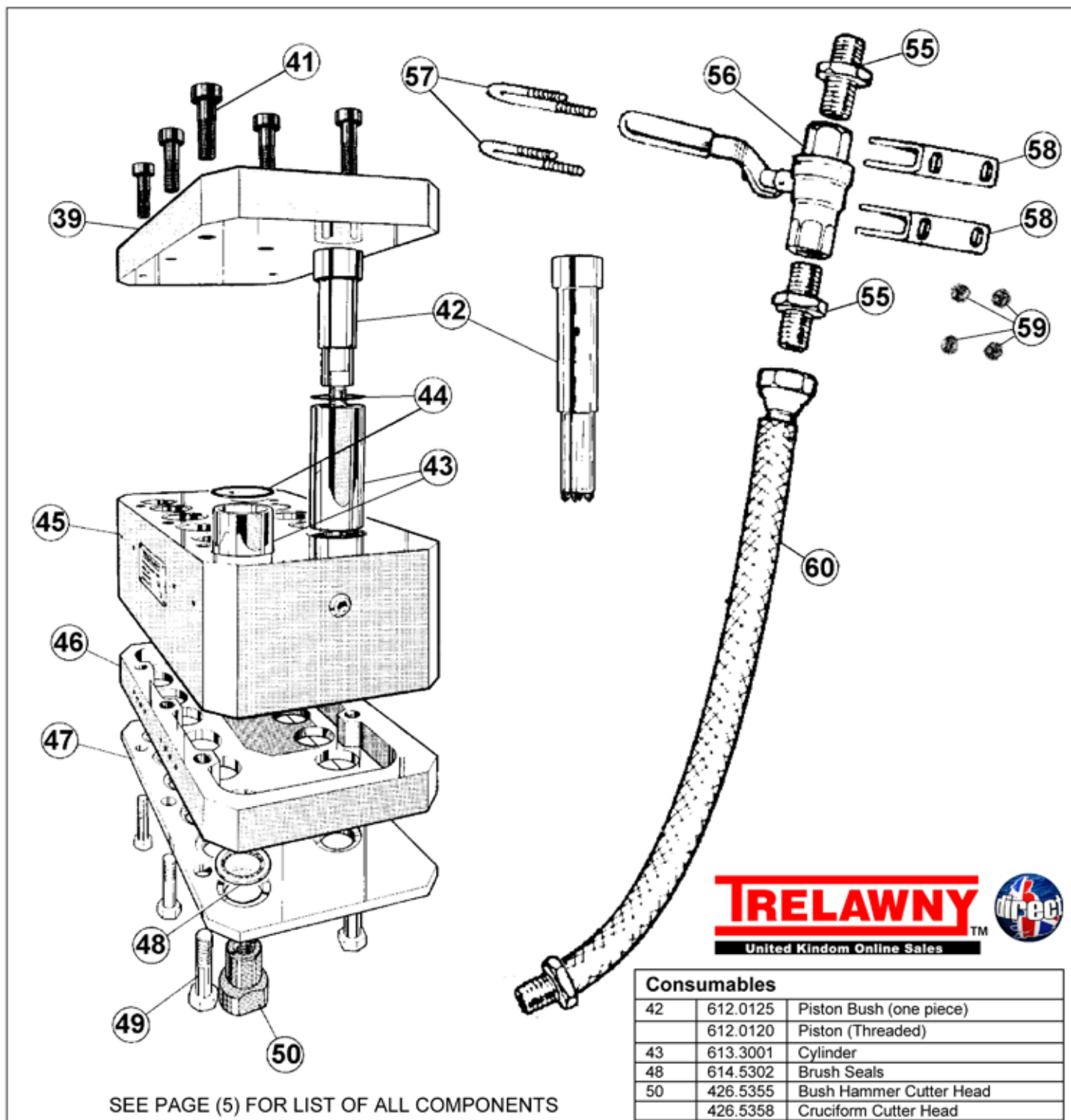

SEE PAGE (5) FOR LIST OF ALL COMPONENTS



Consumables		
42	612.0125	Piston Bush (one piece)
	612.0120	Piston (Threaded)
43	613.3001	Cylinder
48	614.5302	Brush Seals
50	426.5355	Bush Hammer Cutter Head
	426.5358	Cruciform Cutter Head

SERVICING continued

Exploded View 2

TRELAWNYTM
United Kingdom Online Sales

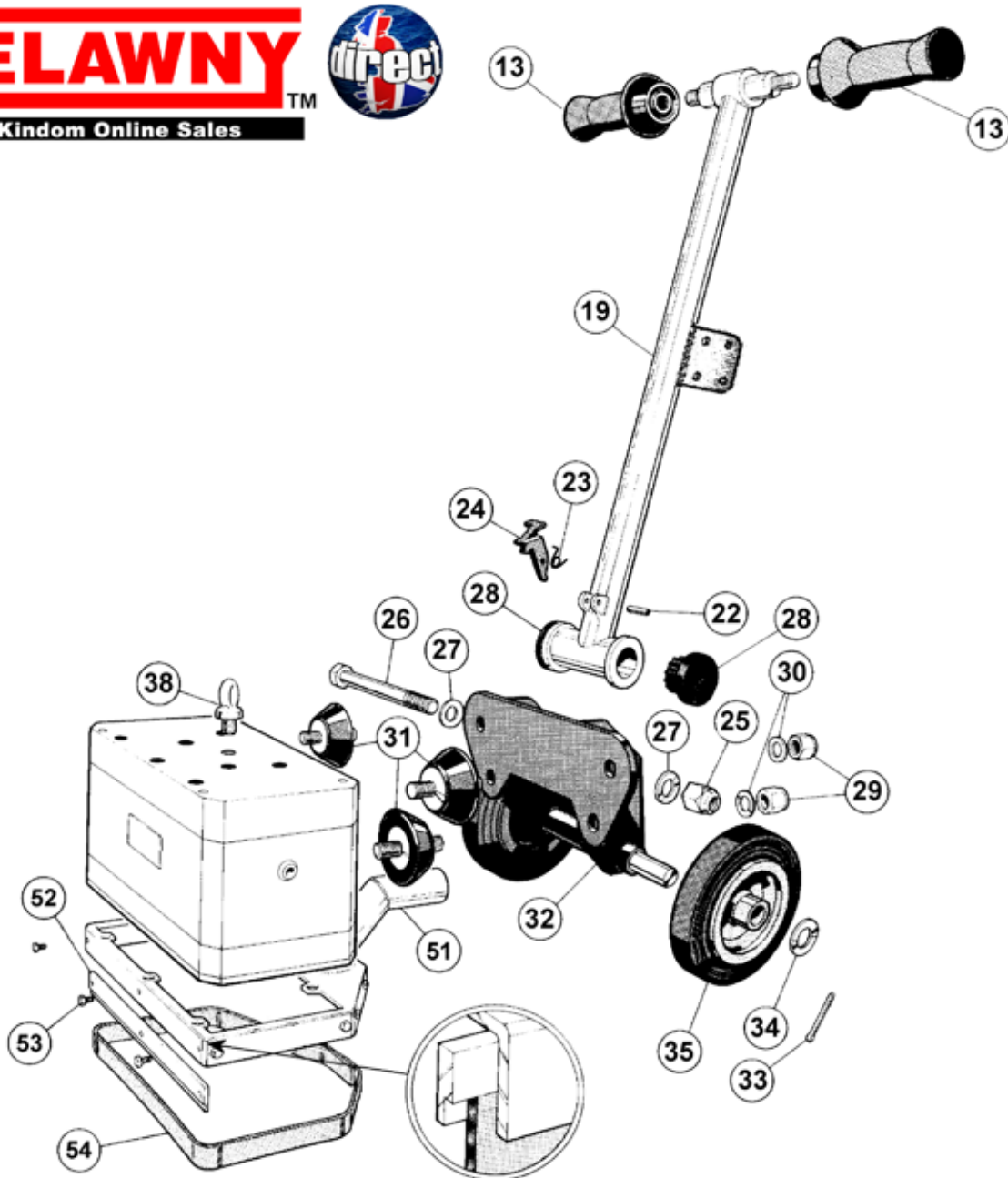

PART NUMBER LIST

Item No	Part No	Description	Item No	Part No	Description
13	490.0200	Hand Grip (set of 2)	43	613.3001	Cylinder
19	422.0120	Prior 2010 - Handle Assembly	44	809.0500	Cylinder 'O'Ring
	422.0125	2010 onwards - Handle Assembly			
22-24	491.4100	Prior 2010 - Foot Release set	47	654.1120	Sealing Plate
	491.4110	2010 onwards - Foot Release set	48	614.5302	Brush Seals
23	714.0120	Prior 2010 - Spring	49	831.3120	Bolt M12 x 65 Hex Head
	713.0125	2010 onwards - Spring		*806.1265	Cap Head Screw M12 x 65 (For Vacuum Shroud)
25-27	491.2000	Handle Pivot Bolt assembly	50	426.5355	Bush Hammer Cutter Head (for 612.0120)
28	490.1000	Rubber Mountings (set of 2)		426.5358	Cruciform Cutter Head (for 612.0120)
29-31	491.0200	Rubber Block mounting kit (set of 4)	51	437.0120	Vacuum Shroud assembly (Inc 52,53,54 and *806.1265)
32	440.0120	Subframe	52	492.0120	Clamp Plates (set of five)
33-35	491.1100	Wheel assembly (set of 2)	53	490.3200	M5 Hexagon Head Screws (Set of 11)
38	831.4120	Eye Bolt	54	731.0120	Vacuum Shroud Seal
39/45/46	491.5000	Cylinder Block	55	826.5004	Adaptor 3/4 BSP x 3/4" BSPT
41	490.3000	Caphead Screw (set of 7)	56	828.1000	Ball Valve
42	612.0125	Piston Bush (one piece)	57-59	491.2100	'U' Bolt assembly (set of 2)
	612.0120	Piston (Threaded)	60	719.0750	Armoured Hose inc fittings

SEE PAGE (4) FOR LIST OF CONSUMABLES

SERVICING continued

Trouble Shooting

FAULT	CAUSE	ACTION
Machine bounces in use	Air pressure too high.	Ensure that the air pressure is set at 90psi. (6.2bar). If the air pressure cannot be controlled, close the MHS11 on/off ball valve off slightly until the machine runs smoothly.
Machine performance slow	Worn Cutter Heads	Replace Cutter Heads (Cutter Head life is approximately 100hrs use)
Machine drags on floor	Insufficient air supply	Ensure that the compressor can supply at least 70cfm (free air) at 90psi in order to avoid air supply problems.
	Hose bore too small	Ensure that the hose bore is 3/4" (19mm).
	Hose run too long	Each 50 ft. (15 mtrs) of airline used, will drop the pressure by approximately 3 psi.
	Worn Pistons and/or cylinders.	Replace piston and cylinders

If problem has not been cured by any of the above actions, contact your local dealership or agent for assistance.

Technical Specifications

Blows per minute	2200 x 11
Air consumption	26.0 l/s (55.0 cfm)
Working height	1295mm (51.0')
Packaged dimensions	305mm W x 356mm L x 813mm H
Weight	70kg (154 lbs)
Air hose bore - (Air Inlet Adaptor 3/4" BSP)	19mm (0.75')
Removal rate *	28m ² /hr (300ft ² /hr)
Depth of cut (Average) *	3.0mm (.118')
Cutting Width	250mm (9.84')
Noise L _{PA} SPL	97.4 dB (A)
L _{WA} SWL	110.5dB (A)
Vibration (AEQ)	5.0m/s ² (K= +40% -0%)

Trelawny SPT Ltd operates a policy of continuous product development and refinement and therefore reserves the right to change technical specifications and product designs without giving prior notice.

*These values are guidelines only. Test concrete surface was one year old and the finish produced suitable for keying additional layers. The aggregate was exposed but not severely damaged or disturbed.

Noise and Vibration Declaration Statement

Declared vibration emission values are in accordance with BS EN 12096: 1997

(K) Equals the factor of uncertainty, which allows for variations in measurement and production.
Vibration data figures are **tri-axial**, which gives total vibration emission.

Risk of Hand Arm Injury

Because of various factors, the range of vibration emission during intended use of this tool is expected to be between 5.0m/s² – 7.0m/s².

The vibration is dependent on the task, the operators grip, and feed force employed etc.

Noise level measured in accordance with EN ISO 15744: 1999

Vibration measured in accordance with EN ISO 28927 and EN ISO 20643

Machinery Directive Information

This tool has been designed and produced in accordance with the following directives:

2006/42/EC Machinery Directive
and applicable harmonised standard: EN ISO 1 1148-4:2010



site: www.trelawnydirect.com
email: sales@trelawnydirect
call: 01698 333200

Trelawny tools are thoroughly tested under specified conditions in accordance with applicable internationally recognised standards. When a tool is used on site the conditions may not be the same as those used in Trelawny tests.

Trelawny Surface Preparation Technology operates a policy of continuous product development and refinement and therefore reserves the right to change technical specifications and product designs without giving prior notice.

© Copyright 2009, Trelawny SPT Limited, CV31 1XT, UK All rights reserved. Any unauthorised use or copying of the contents or part thereof is prohibited. This applies to trademarks, model denominations, part numbers and drawings. Use only genuine Trelawny spares.

The use of non-Trelawny spare parts invalidates the warranty.